

# KOMATSU®

## WA450-5

**NET HORSEPOWER**  
195 kW **261 HP** @ 2000 rpm

**OPERATING WEIGHT**  
22355– 23770 kg  
**49,282– 52,404 lb**

**BUCKET CAPACITY**  
3.6–5.2 m<sup>3</sup> **4.7–6.8 yd<sup>3</sup>**

**WA**  
**450**



**WHEEL LOADER**

**GALEO**

# WA450-5 Wheel Loader

## WALK-AROUND

**Komatsu-integrated design** offers the best value, reliability, and versatility. Hydraulics, powertrain, frame, and all other major components are engineered by Komatsu. You get a machine whose components are designed to work together for higher production, greater reliability, and more versatility.

**Reversible, variable speed hydraulic radiator fan** and swing-out coolers.

**Full side opening** gull-wing engine doors.

Optional **lockup torque converter**.

**Automatic transmission** with four selectable shifting modes.

Powerful yet efficient Komatsu SAA6D125E-3 **emissionized engine**.

**Adjustable** transmission cut-off system.

**18% larger cab** with new layout design.

Two-mode **engine power select system**.



**Staircase-type steps** with large rear-hinged doors.

# WA450-5

WHEEL LOADER

**NET HORSEPOWER**  
195 kW 261 HP @ 2000 rpm

**OPERATING WEIGHT**  
22355 – 23770 kg  
49,282– 52,404 lb

**BUCKET CAPACITY**  
3.6–5.2 m<sup>3</sup>  
4.7–6.8 yd<sup>3</sup>

**Air conditioning, air-ride seat**  
and **ride control** are standard features for  
increased operator comfort.

**Expanded main monitor**  
and troubleshooting display.

**Reduced operator noise**  
to 71 dB(A).

**Telescopic/tilt**  
steering column.

**Fingertip control** levers.

Optional **joystick steering**.



**Dual-speed**  
hydraulic system.

Optional **load meter**  
integrated on main  
monitor.

**Ground level servicing**  
and fluid checks.

**Extended service intervals.**

## GALEO

Komatsu's highly productive, innovative  
technology, environmentally friendly  
machines built for the 21<sup>st</sup> century.

# PRODUCTIVITY FEATURES

## High Productivity and Low Fuel Consumption

### Powerful Engine

The electronically controlled fuel injection timing in the SAA6D125E-3 engine provides optimum combustion of fuel at both low and high speed/power applications. This system also provides fast throttle response to match the machine's powerful rim pull and fast hydraulic response.

### 261 HP, 195 kW

The common rail type fuel injection system provides maximum power with minimum emissions. This engine is EPA Tier 2 emission ready.

### Low Fuel Consumption

The fuel consumption has been reduced 15% due to the high-torque engine and the large-capacity torque converter with maximum efficiency in the low-speed range.

### Two Mode Engine Power Select System

This wheel loader offers two selectable engine operating modes — Normal and Power. The operator can adjust the machine's engine performance to match the condition requirements. This system is controlled with a dial on the right side control panel.

- **Normal Mode:** Provides maximum fuel efficiency for most general loading conditions.
- **Power Mode:** Provides maximum power output for hard digging conditions or hill climb operations.



### Automatic Transmission with Four Mode Select System

This operator controlled system allows the selection of manual shifting or three levels of automatic shifting modes (low, medium, and high). The operator can match the machine's operating requirements with optimum performance efficiency. This system is controlled with a dial on the right side of the control panel.

- **Manual:** The transmission is fixed to the gear speed and selected with the gear shift lever.

- **Auto Low:** Low mode provides smooth gear shifting at low engine speeds suitable for general excavating and loading while offering reduced fuel consumption.
- **Auto Medium:** Medium mode provides gear shifting at mid-range engine speeds required for more aggressive conditions.



- **Auto High:** High mode provides maximum rim pull and fast cycle times by shifting the transmission at high engine speeds. This mode is suitable for hill-climb and load and carry operations.

### Variable Transmission Cut-Off

The operator can select the transmission cut-off pressure desired for the left brake pedal using the switch located on the right-side control panel.

- Higher cut-off pressure allows the transmission to remain engaged at higher engine rpm/hydraulic pressure for increased performance in ramp loading and stockpiling operations.
- Lower cut-off pressure disengages the transmission at lower rpm/hydraulic pressure for more fuel efficient operation on level surfaces.

### Lockup Torque Converter

The Komatsu designed lock-up torque converter provides increased production efficiency, reduced cycle times and optimum fuel savings in load and carry or hill-climb operations.

This optional feature allows the operator to activate the system on or off with a switch located on the right-side control panel. When the system is activated, the torque converter will automatically lock-up when the travel speed reaches 10.9 km/h **6.8 mph** in third gear or 20.9 km/h **13.0 mph** in fourth gear.

### Joystick Steering

Komatsu's optional joystick steering provides fast, precise operator control for V-type cycle loading. The Komatsu joystick steering system has both a steering wheel and joystick combination to comfortably fit all operator preferences and operating conditions.

The Komatsu joystick steering control lever has conveniently located gear upshift/downshift switches, a F/N/R directional change switch, a high/low articulation speed mode switch and a horn switch.

### Transmission Hold Switch

This feature compliments the automatic transmission by allowing the operator to hold the transmission in a desired gear by simply pressing a button on the side of the boom lever.

### Transmission Kick-Down Switch

This feature provides increased rimpull, bucket pile penetration and reduced cycle times. The operator can press a button on the top of the boom lever to downshift the transmission from second to first gear when digging into the pile. The transmission automatically shifts into second gear when changing into reverse gear.

The Kick-down switch has two new functions:

1. Downshift function one gear at a time from 4th gear to 1st when in automatic shift mode.
2. Increased rimpull in uphill ramp loading applications.

### Dual-Speed Hydraulic System

Komatsu's automatic dual-speed hydraulic system increases operational efficiency and productivity by matching the hydraulic demands to the work conditions.

### Digging Operations

Engine power used to operate the switch pump is transferred to the transmission to provide increased rimpull when digging.

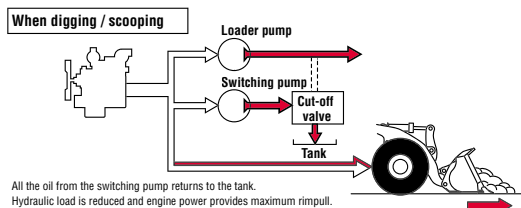

### Lifting Operations

The switch pump assists the loader pump to provide increased lifting speed and power when lifting and loading.

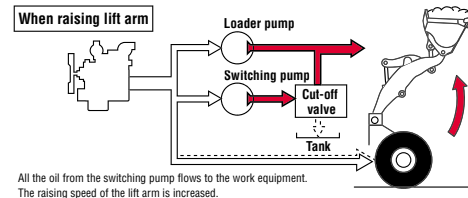

### ECSS Ride Control

Ride control is a standard feature for Komatsu and is ideal in load and carry operations. The ECSS provides a smooth ride in rough ground surfaces which optimizes productivity by improving material retention in the bucket and increasing operator comfort and control.

### Load Meter

The new optional Komatsu load meter is now integrated into the main monitor display panel for improved readability and efficiency.

The subtotal and cancel switches are located on the bucket control lever for easy operator function. Komatsu also offers a paper printer option to use with the load meter to record the weight of the material loaded.



# INCREASED RELIABILITY AND SERVICEABILITY

## Komatsu Components

Komatsu manufactures the engine, torque converter, transmission, hydraulic units, and electrical parts on this wheel loader.

Komatsu loaders are manufactured with an integrated production system under a strict quality control system.

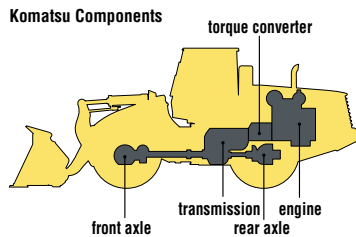

## Reversible Hydraulic Radiator Fan and Swing-Out Coolers

The new Komatsu cooling system is isolated from the engine to provide more efficient cooling and easier cleaning. The variable speed hydraulic fan is reversible to allow the operator to quickly clean out the cooling system by turning on a switch located on the right side control panel. The reversible

fan, swing-out air-to-air and oil coolers along with the swing-up rear grill and bottom flush-out gates allow the operator to easily clean the radiator system in adverse operating conditions. The variable speed hydraulic fan is temperature activated to provide cooling on demand and reduce fuel consumption.

## Full Side-Opening Gull-Wing Engine Doors

Ground level engine service and daily service checks are made easy with the gas spring assisted full side opening gull-wing doors.

## Extended Service Intervals

The new clean running Komatsu SAA6D125E-3 emissionized engine provides fuel efficient power and extended engine oil and filter service intervals; increased from 250 hours to 500 hours.

Improved drive-shaft seals also allow extended greasing intervals from 1000 hours to 4000 hours.



### Sealed DT Connectors

Main harnesses and controller connectors are equipped with sealed DT connectors providing high reliability, dust and corrosion resistance.

### Flat Face-to-Face O-Ring Seals

Flat face-to-face O-ring seals are used to securely seal all hydraulic hose connections and prevent oil leakage.

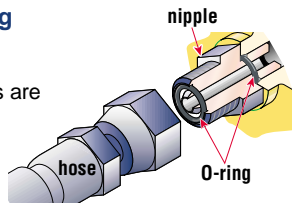

### Cylinder Buffer Rings

Buffer rings are installed to the head-side of the all-hydraulic cylinders to lower the load on the rod seals, prolong cylinder life by 30% and maximize overall reliability.

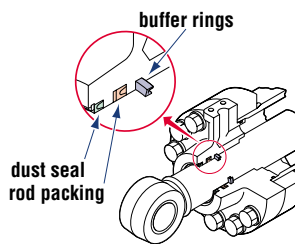

### Main Monitor - EMMS (Equipment Management Monitoring System)

Komatsu's new main monitor keeps the operator informed of all machine functions at a glance. The monitor is located behind the steering wheel and displays 38 different machine functions including fluid/filter change intervals and troubleshooting memory display functions. The main gauges are analog type for easy viewing and other functions utilize lighted symbols or LCD readouts.

### Cathion Electrodeposition Primer Paint/Powder Coating Final Paint

Cathion electrodeposition paint is applied as a primer paint and powder coating is applied as a topcoat to the exterior metal sheet parts. This process results in a durable rust-free machine, even in the most severe environments. Some external parts are made of plastic to provide long life and high impact resistance.

### Wet Multi-Disc Brakes and Fully Hydraulic Braking System

results in lower maintenance costs and higher reliability. The wet disc service and parking brakes are fully sealed and adjustment-free to reduce contamination, wear and maintenance. Added reliability is designed into the braking system by the use of two independent hydraulic circuits providing hydraulic backup should one of the circuits fail. If the brake oil pressure drops, a warning lamp flashes and an alarm sounds intermittently. If the brake pressure continues to drop, the parking brake is automatically applied providing a double safety system.

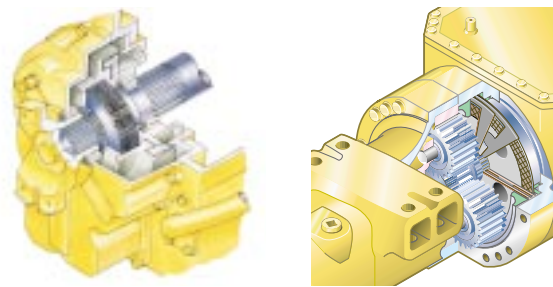

### High-Rigidity Frames

The front and rear frames along with the loader linkage have high rigidity to withstand repeated twisting and bending loads to the loader body and linkage. Both the upper and lower center pivot bearings use tapered roller bearings for increased durability.



# OPERATOR COMFORT

## **New Cab Layout**

Komatsu's new cab layout provides the operator with a roomy, quiet and efficient work environment. The cab has 123 cubic feet of space and large flat glass for optimum visibility. The low noise level inside the cab leads the industry at 71 dB(A) and loader controls are ergonomically designed to reduce operator fatigue and increase productivity.

## **Fingertip Control Levers**

Komatsu now offers fingertip operated hydraulic control levers mounted on an adjustable control panel and wrist rest. This new feature matches well with the pilot pressure controlled hydraulics to reduce operator fatigue, improve fine work equipment control and increase overall productivity. The hydraulic boom and bucket control levers also feature the kickdown switch, transmission hold switch and load meter functions.

## **Two Door Walk-Through Cab**

Entry and exit into the new Komatsu cab starts with sloped staircase type steps and large diameter handrails for added safety and comfort. The large cab doors are rear-hinged to open 130 degrees offering easy entry/exit and will not hamper visibility when operating the machine with the doors latched open.



## **Telescopic/Tilt Steering Column**

The operator can both tilt and telescope the steering wheel to allow maximum comfort and control. The two-spoke steering wheel allows maximum visibility of the monitor panel and the forward work environment.



### Comfortable High-Back Air-Ride Bucket Seat

Long work days and rough work environments will seem short and comfortable on the new air-ride fabric seat. This standard feature seat offers eleven-way adjustments, arm-rest, headrest and lumbar support for any size operator. The retractable seat belt and rear document holder help to keep the cab clean and organized.

### Electrically Controlled Transmission Levers

The Komatsu two-lever electronic shift control levers provide easy gear selection and directional changes. The transmission levers can be operated without removing the operator's hand from the steering wheel, allowing improved comfort and control. This system coupled with the automatic transmission, kickdown switch, transmission hold switch and joystick

steering, offers a variety of transmission shifting options available to match the operator preference and the working conditions.

### Centralized Switch Panel

The centralized switch panel is conveniently located on the right hand side of the operator's work station allowing easy access to the machine's functions such as the key switch, transmission mode, power mode and other switch controls.

### Comforts of Home

The large cab allows room for a large lunch box holder, a variety of cup and bottle holders and a hot/cold box storage area. Standard air conditioning and the optional AM/FM stereo cassette system create a comfortable and controlled work environment.



# SPECIFICATIONS



## ENGINE

Model .....Komatsu SAA6D125E-3  
 EPA Tier 2 emission ready  
 Type .....Water-cooled, 4-cycle  
 Aspiration .....Air-to-air aftercooled, turbocharged  
 Number of cylinders .....6  
 Bore x stroke .....125 mm x 150 mm **4.9" x 5.9"**  
 Piston displacement .....11.04 ltr **674 in<sup>3</sup>**  
 Horsepower rating @ 2000 rpm (SAE J1349)  
 Gross power .....205 kW **274 HP**  
 Flywheel/net power .....195 kW **261 HP**  
 Fuel system .....Direct injection  
 Governor .....Electronic, all-speed control  
 Lubrication system:  
 Lubrication method .....Gear pump, force-lubrication  
 Filter .....Full-flow type  
 Air cleaner .....Dry type with double radial-sealed elements  
 and dust evacuator, plus dust indicator



## TRANSMISSION

Torque converter:  
 Type .....3-element, single-stage, single-phase  
 Transmission:  
 Type .....Full-powershift, countershaft type  
 Travel speed (measured with 26.5-25 tires):

	1st		2nd		3rd		4th	
	km/h	mph	km/h	mph	km/h	mph	km/h	mph
Forward	6.3	<b>3.9</b>	12.1	<b>7.5</b>	21.7	<b>13.5</b>	34.9	<b>21.7</b>
Reverse	6.7	<b>4.2</b>	12.8	<b>8.0</b>	23.0	<b>14.3</b>	36.0	<b>22.4</b>



## AXLES AND FINAL DRIVES

Drive system .....Four-wheel drive  
 Front .....Fixed, semi-floating  
 Rear .....Center-pin support, semi-floating,  
 30° total oscillation  
 Reduction gear .....Spiral bevel gear  
 Differential gear .....Conventional type  
 Final reduction gear .....Planetary gear, single reduction



## BRAKES

Service brakes .....Hydraulically actuated, in-board mounted  
 wet multi-disc brakes actuate on four wheels  
 Parking brake .....Wet multi-disc brake



## STEERING SYSTEM

Type .....Articulated type, full-hydraulic power steering  
 Steering angle .....40° each direction  
 Minimum turning radius at  
 the center of outside tire .....5900 mm **19'4"**



## HYDRAULIC SYSTEM

Steering system:  
 Hydraulic pump .....Gear pump  
 Capacity .....146 ltr/min **38.6 U.S. gal/min** at rated rpm  
 Relief valve setting .....210 kgf/cm<sup>2</sup> **3,000 psi**  
 Hydraulic cylinders:  
 Type .....Double-acting, piston type  
 Number of cylinders .....2  
 Bore x stroke .....100 mm x 441 mm **3.9" x 17.3"**  
 Loader control:  
 Hydraulic pump .....Gear pump  
 Capacity .....303 + 120 ltr/min **80.0 + 31.7 U.S. gal/min**  
 at rated rpm  
 Relief valve setting .....210 kgf/cm<sup>2</sup> **3,000 psi**  
 Hydraulic cylinders:  
 Type .....Double-acting, piston type  
 Number of cylinders—bore x stroke:  
 Boom cylinder .....2—180 mm x 764 mm **7.1" x 30.0"**  
 Bucket cylinder .....1—200 mm x 575 mm **7.9" x 22.6"**  
 Control valve .....2-spool type  
 Control positions:  
 Boom .....Raise, hold, lower, and float  
 Bucket .....Tilt-back, hold, and dump  
 Hydraulic cycle time (rated load in bucket)  
 Raise .....6.0 sec  
 Dump .....1.4 sec  
 Lower (empty) .....3.7 sec  
 Total .....11.1 sec



## SERVICE REFILL CAPACITIES

Cooling system .....50 ltr **13.2 U.S. gal**  
 Fuel tank .....390 ltr **103.0 U.S. gal**  
 Engine .....38 ltr **10.0 U.S. gal**  
 Hydraulic system .....186 ltr **49.1 U.S. gal**  
 Axle (each front and rear) .....52 ltr **13.7 U.S. gal**  
 Torque converter and transmission .....60 ltr **15.9 U.S. gal**



## BUCKET SELECTION GUIDE

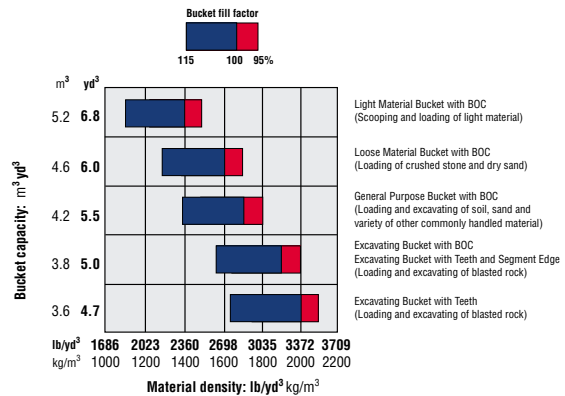

# WA450-5

## WHEEL LOADER



Measured with 26.5-25-20PR (L3) tires

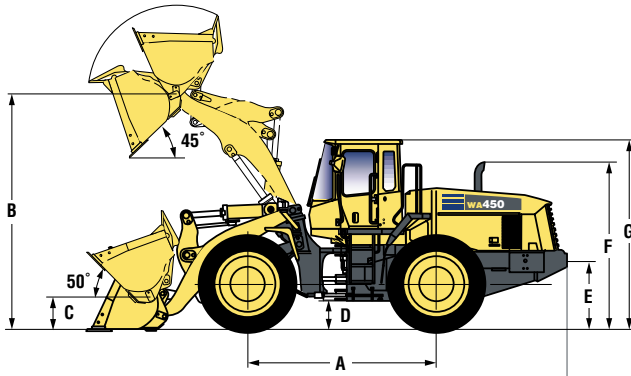

Tread	2300 mm	7'7"
Width over tires	3010 mm	9'11"
A Wheelbase	3450 mm	11'4"
B Hinge pin height at Max. height:	Standard Boom	4360 mm 14'4"
	High Lift Boom	4870 mm 16'0"
C Hinge pin height at carry position:	Standard Boom	585 mm 1'11"
	High Lift Boom	730 mm 2'5"
D Ground clearance	525 mm	1'9"
E Hitch height	1240 mm	4'1"
F Overall height, top of stack	3080 mm	10'2"
G Overall height ROPS cab	3460 mm	11'4"

Bucket		General Purpose Bolt-on Cutting Edge		Excavating with Teeth		Light Material Bolt-on Cutting Edge		High Lift Boom, G.P. Bolt-on Cutting Edge	
Bucket Capacity	Heaped	4.2 m <sup>3</sup>	5.5 yd <sup>3</sup>	3.6 m <sup>3</sup>	4.7 yd <sup>3</sup>	5.2 m <sup>3</sup>	6.8 yd <sup>3</sup>	3.8 m <sup>3</sup>	5.0 yd <sup>3</sup>
	Struck	3.5 m <sup>3</sup>	4.6 yd <sup>3</sup>	3.1 m <sup>3</sup>	4.1 yd <sup>3</sup>	4.5 m <sup>3</sup>	5.9 yd <sup>3</sup>	3.2 m <sup>3</sup>	4.2 yd <sup>3</sup>
Bucket Width		3170 mm	10'5"	3170 mm	10'5"	3170 mm	10'5"	3170 mm	10'5"
Bucket Weight		2050 kg	4,519 lb	2070 kg	4,564 lb	2185 kg	4,817 lb	2150 kg	4,740 lb
Static Tipping Load	Straight	17985 kg	39,722 lb	17965 kg	39,605 lb	17850 kg	39,351 lb	14485 kg	31,934 lb
	40° full turn	15610 kg	34,413 lb	15590 kg	34,369 lb	15475 kg	34,096 lb	12605 kg	27,789 lb
Dumping Clearance, maximum height and 45° dump angle		3185 mm	10'6"	3110 mm	10'3"	3035 mm	10'0"	3625 mm	11'11"
Reach at 7' 2130 mm 45° dump angle		1980 mm	6'6"	2040 mm	6'8"	2130 mm	7'0"	2465 mm	8'1"
Reach at maximum height and 45° dump angle		1235 mm	4'1"	1355 mm	4'5"	1455 mm	4'9"	1455 mm	4'9"
Operating Height	Fully raised	5960 mm	19'7"	5875 mm	19'4"	6185 mm	20'4"	6420 mm	21'1"
Overall Length	Bucket at carry	8815 mm	28'11"	8900 mm	29'2"	9025 mm	29'7"	9560 mm	31'5"
Turning Radius*		6980 mm	22'11"	7020 mm	23'0"	7040 mm	23'1"	7290 mm	23'11"
Digging Depth	0°	80 mm	3.2"	100 mm	3.9"	80 mm	3.2"	235 mm	9.3"
	10°	315 mm	1'0"	355 mm	1'2"	350 mm	1'2"	485 mm	1'7"
Breakout Force		192 kN	43,162 lb	220 kN	49,456 lb	165 kN	37,092 lb	197 kN	44,250 lb
Operating Weight		22355 kg	49,282 lb	22375 kg	49,326 lb	22490 kg	49,579 lb	23770 kg	52,404 lb

\*At the end of tooth or B.O.C.

All dimensions, weights, and performance values based on SAE J732c and J742b standards. Static tipping load and operating weight shown include lubricant, coolant, full fuel tank, ROPS cab, additional counterweight, and operator. Machine stability and operating weight affected by counterweight, tire size, and other attachments.

### Weight Changes

Tires	Operating weight		Tipping load straight		Tipping load full turn		Width over tires		Ground clearance		Change in vertical dimensions	
	kg	lb	kg	lb	kg	lb	mm	ft in	mm	ft in	mm	ft in
26.5-25-20PR(L-4)	+425	+937	+330	+728	+290	+639	3010	9'11"	525	1'9"	+65	3"
Remove ROPS cab	-660	-1,455	-610	-1,345	-590	-1,300						
Install ROPS canopy	+430	+950	+360	+795	+345	+760						
Remove additional counterweight	-400	-880	-950	-2094	-790	-1742						



## STANDARD EQUIPMENT

- 2-spool valve for boom and bucket controls
- Air cleaner, 2-stage dry with auto dust evacuator, plus dust indicator (radial-sealed)
- Alternator, 50 A, 24V, 1000 CCA
- Auto shift transmission with mode select system
- Axle, semi floating with conventional differentials
- Back-up alarm
- Batteries, 150 Ah/2 x 12 V
- Boom kick-out
- Bucket positioner
- Cab (ROPS/FOPS) with adjustable wrist rests, adjustable work equipment levers, cigarette lighter/ash tray, dome light, electrically heated rear window, air conditioner and hot/cold box, heater/defroster/pressurizer, floor mat, front (intermittent) and rear wiper/washer, rearview mirrors (2 outside, 2 inside), right hand and left hand door access with steps, sun visor
- Centralized grease banks
- Counterweight
- ECSS (Electronically Controlled Suspension System)
- EMMS (Equipment Management Monitoring System)
  - Gauges (Speedometer/tachometer, engine water temperature, fuel level, hydraulic temperature, torque converter temperature)
  - LCD displays (service meter/ troubleshooting, shift indicator)
  - Lights (central warning, brake oil pressure, engine oil pressure, engine oil level, air cleaner restriction, parking brake, axle oil temperature, reverse cooling fan, oil change required, battery electrolyte level, radiator water level, engine preheat, battery charge, steering oil pressure, auxiliary steering, power mode, joystick steering option, directional indicator, auto shift, torque converter lock-up option, shift hold, gear position, torque converter temperature, engine water temperature, turn signals, high beam, rpm/mph display, hydraulic temperature, fuel level)
- Engine, Komatsu SAA6D125E-3 diesel
- Engine shut-off system, electric
- Engine water conditioner
- Fenders, full front, partial rear
- Horn, electric
- Hydraulic-driven fan, reversible, variable speed
- Lift cylinders and bucket cylinder
- Lifting eye
- Lights
  - Stop and tail
  - Turn signal, 2 front, 2 rear with hazard switch
  - Working lights, halogen (2 front, high-low beam with indicator, fender mount, 2 rear, 2 front, outside mount)
- Loader linkage with standard lift arm
- Parking brake, wet multi-disc
- PPC fingertip control, two levers
- Radiator mask, lattice type
- Seat, fabric, air suspension, reclining, armrests
- Seat belt, 76 mm 3" width, retractable
- Service brakes, wet disc type
- Starting aid, air intake manifold pre-heater
- Starting motor, 7.5 kW/24 V
- Steering wheel, tiltable, telescopic
- Swing-out aftercooler and oil cooler
- Tires (26.5-25-20PR, L3 tubeless) and rims
- Tool box (in battery box)
- Transmission, 4 forward and 4 reverse
- Vandalism protection kit
- Voltage converter, 5 A, 12 V



## OPTIONAL EQUIPMENT

- 3-spool valve, with lever and piping
- Additional counterweight
- AM/FM stereo radio cassette
- Auxiliary steering
- Bucket, excavating, with BOCE 3.9 m<sup>3</sup> **5.0 yd<sup>3</sup>**
- Bucket, general purpose, with BOCE 3.9 m<sup>3</sup> **5.0 yd<sup>3</sup>** (high lift)
- Bucket, general purpose, with BOCE 4.2 m<sup>3</sup> **5.5 yd<sup>3</sup>**
- Bucket, light material, with BOCE 5.2 m<sup>3</sup> **6.8 yd<sup>3</sup>**
- Bucket teeth (bolt-on type)
- Counterweight for logging arrangement
- Cutting edge (bolt-on type)
- Decals, French
- Engine pre-cleaner with extension
- Heater/defroster/pressurizer
- High lift boom arrangement
- Joystick steering
- JRB bucket, general purpose, for use with coupler, with BCOE 4.0 m<sup>3</sup> **5.25 yd<sup>3</sup>**
- JRB bucket, multi-purpose, for use with coupler, with BCOE 3.6 m<sup>3</sup> **4.73 yd<sup>3</sup>**
- JRB extendable boom, 2-section for use with coupler
- JRB construction forks for use with coupler 1829 mm **72"**
- JRB hydraulic quick coupler
- Limited slip differential (F&R)
- Load meter
- Lock-up clutch torque converter
- Logging arrangement
- Printer for load meter
- Rear full fenders
- ROPS/FOPS open canopy
- Single lever, multi-function loader and transmission control
- Suspension seat, vinyl
- Tires, radial
  - 26.5-R25 VMT L3 Bridgestone
  - 26.5-R25 XHA 1-Star L3 Michelin
  - 26.5-R25 XLDD1A 1-Star L4 Michelin
  - 26.5-R25 XLDD2A 1-Star L5 Michelin
  - 26.5-R25 XMINED2 L5 Michelin
- Tires, bias
  - 26.5-25, 20PR, L4
  - 26.5-25, 20PR, L5
  - Brand preference (Goodyear)

AE5583-03

©2003 Komatsu Printed in USA

DK4(10M)C

04/03 (EV-1)

# KOMATSU®

440 N. Fairway Drive  
P.O. Box 8112  
Vernon Hills, IL 60061

