

KOMATSU®

FLYWHEEL HORSEPOWER @ 2000 rpm
D31EX/PX-21 56 kW **75 HP**

OPERATING WEIGHT
D31EX-21 7130 kg **15,720 lb**
D31PX-21 7650 kg **16,870 lb**

D31EX-21

D31PX-21



D
31



CRAWLER DOZER

Photos may include optional equipment.

GALEO

D31EX/PX-21 Crawler Dozer

WALK-AROUND

The Komatsu SAA4D102E-2 turbocharged and aftercooled diesel engine provides an output of 56 kW **75 HP** with excellent productivity, while meeting Tier II EPA, EU, and Japan emissions regulations.

Palm Command Control System (PCCS)
Left hand controls all tractor motion. Right hand controls all blade movements.

Gull-wing engine side doors for easy and safer servicing.

Hydrostatic steering utilizes a PPC valve to facilitate smooth shockless steering control.

Radiator Nose
Sound deflection style for reduced ambient noise.

High capacity
Power Angle Tilt dozer
combines the highest power in its class with outstanding productivity.

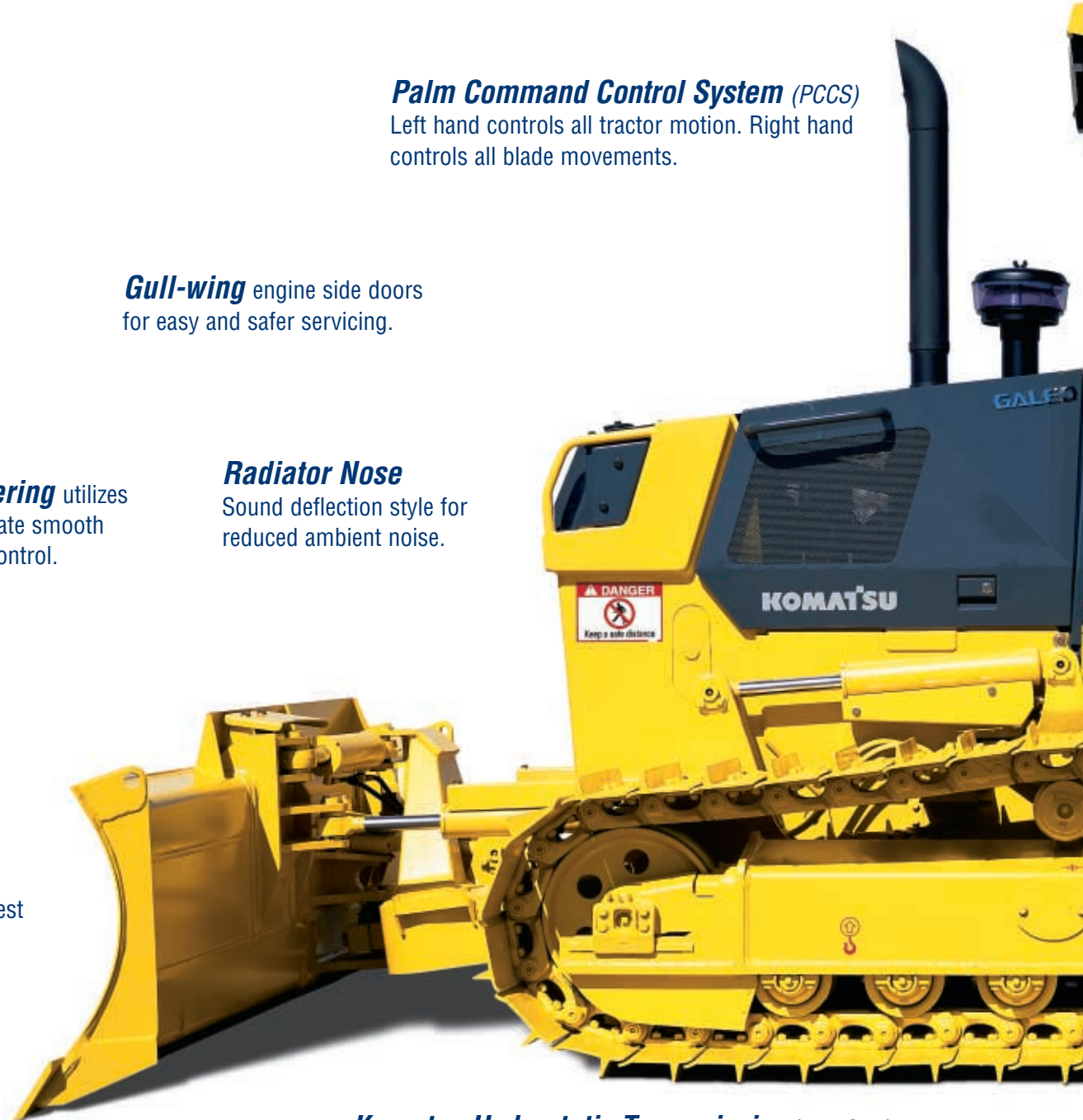

Blade tilt lines
completely protected.

Komatsu Hydrostatic Transmission (KomStat)
offers palm control of speed (3 forward and 3 reverse), turn, directional changes, and power steering with PPC valve control.

D31EX/PX-21

CRAWLER DOZER

FLYWHEEL HORSEPOWER
@ 2000 rpm
D31EX/PX-21: 56 kW 75 HP

OPERATING WEIGHT
D31EX: 7130 kg 15,720 lb
D31PX: 7650 kg 16,870 lb

BLADE CAPACITY
PAT Dozer:
D31EX: 1.26 m³ 1.65 yd³
D31PX: 1.34 m³ 1.75 yd³

Electronic Monitoring System

prevents minor problems from developing into major ones.

Optional quadrangle design, low noise pressurized ROPS cab

One-piece front glass window offers exceptional front, side, and rear visibility.



Photo may include optional equipment.

Intermediate speed selection enables setting of optimum travel speed to job conditions, improving grading accuracy.



Final drives and travel motors

are completely protected.

Bolt-on sprocket

for ease of maintenance.

Modular power train for increased serviceability and durability.

GALEO

Komatsu's highly productive, innovative technology, environmentally friendly machines built for the 21st century.

ENGINE AND HYDROSTATIC TRANSMISSION



Komatsu SAA4D102E-2 Turbocharged and Aftercooled Diesel Engine

Powerful Engine

A powerful SAA4D102E-2 turbocharged air-to-air aftercooled diesel engine provides a massive output of 56 kW **75 HP** for D31EX/PX-21. This engine meets Tier II EPA, EU, and Japan emissions regulations, without sacrificing power or machine productivity.

The engine power is transmitted via a high-efficiency KomStat Hydrostatic Transmission to the final drives.

KomStat Hydrostatic Transmission (HST)

3-speed HST

The D31EX/PX-21 is equipped with Komatsu's exclusive KomStat Hydrostatic Transmission (HST). D31-21 HST consists of dual-path closed-circuit system with two variable displacement piston pumps and two 3-speed variable displacement travel motors. The 3-speed variable capacity travel motors allow the operator to select the optimum speed to match specific jobs.

Automatic Shift Between 1st and 2nd Speeds

KomStat shifts automatically between 1st and 2nd speed depending on load or ground conditions to facilitate efficient operation.

Intermediate Speed Selection

Enables the setting of intermediate speed in each speed range as operator desires or optimum travel speed to match job conditions.

This means, for example, intermediate speeds of 1st speed (4.3 km/h **2.7 mph**), such as 3.0 km/h **1.9 mph** etc., are obtained by using the newly developed PPC valve with friction disc clutch. This contributes to increased job efficiency on fine or rough grading operation with optimum travel speed to match job conditions.

HST Dynamic Brakes

D31EX/PX-21 uses HST dynamic brakes to ensure safe operation. Parking brake is wet, multiple-disc type with a unique drag-prevention control to keep hydraulic oil clean.

Benefits of the HST system

- **Grading operation**
Optimum travel speed is easily selectable making grading operations more efficient.
- **Dozing operation while turning**
The power from the engine is transmitted to both tracks while turning (power turn) enabling dozing operations during turns to be carried out efficiently at the same speed as straight dozing.
- **Side-cut operation**
It is easy to control machine, even with a load on one side of the blade. This enables the operator to perform side-cut operation efficiently and accurately.
- **Operation on slope**
Countersteering during turns is not required during dozing operations on slopes. Dozing on slopes and on flat ground are conducted in the same way.
- **Approaching operation with very low speed**
Travel speed can be infinitely controlled without throttling engine speed. This facilitates approaches to material at low speed without the engine stopping.
- **Operation on soft ground**
There is no power interruption during smooth drawbar pulls, providing excellent traction on soft ground.

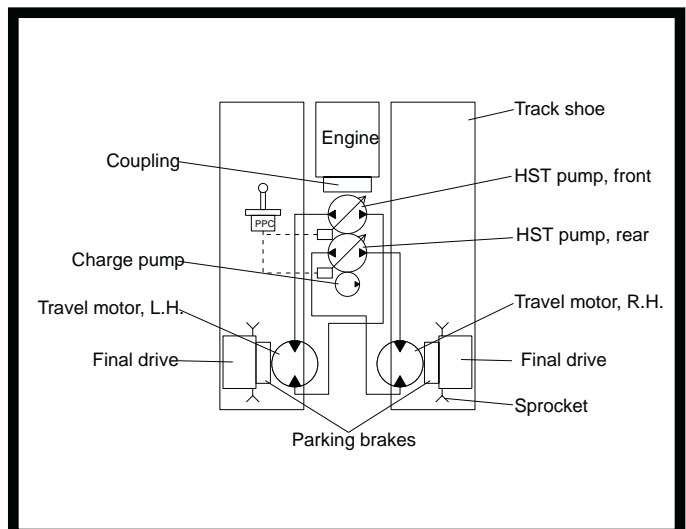
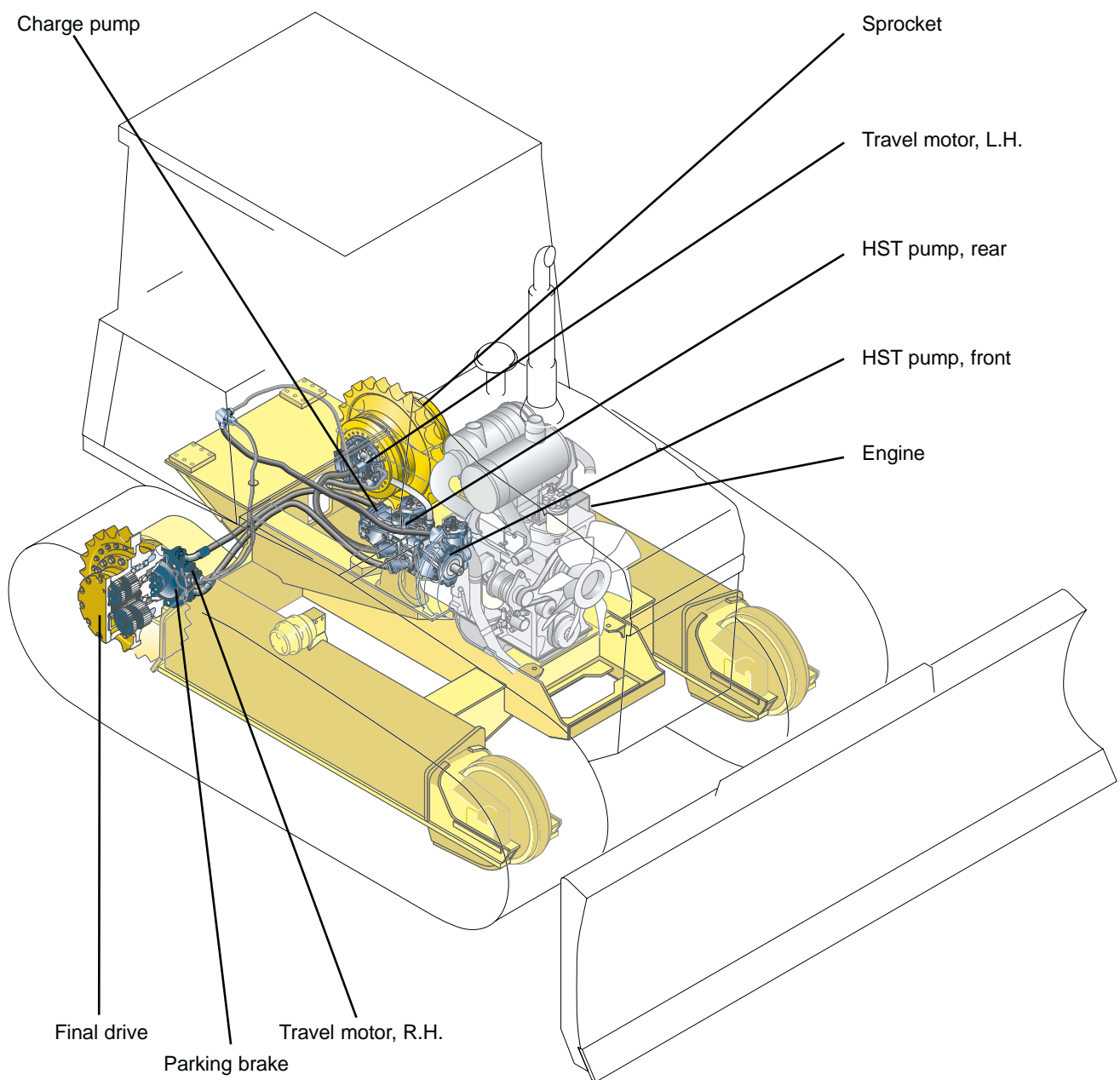

EXCELLENT GRADING ABILITY

Outstanding Stability

The large ground contact area created by the long tracks and wide track gauge combines with a low center of gravity to make the D31EX/PX-21 a stable and well-balanced machine that can perform precise grading work on rough or inclined terrain.

Exceptional Blade Visibility

The slim engine hood and well-located operator seat provide excellent visibility to the blade. This clear blade visibility greatly increases grading efficiency and reduces operator guesswork. Finish grading and rough grading can be performed easily, drastically reducing cycle times.

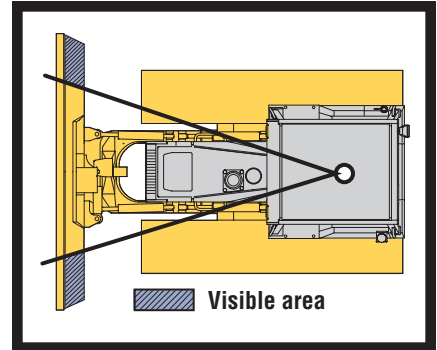

Superb Steering Accuracy

The KomStat steering system offers smooth steering performance even in gradual turns, permitting the D31EX/PX-21 to approach dozing objects accurately in corner grading and side wall operations.



Palm Command Control System

Ergonomically designed Palm Command Control System (PCCS) joystick controls all directional movements. Pushing the joystick forward results in forward machine travel, while pulling it rearward reverses the machine. Simply tilt the joystick to the left to make a left turn. Tilt it to the right for a right turn. Hydrostatic steering eliminates steering clutches and brakes, providing smooth, powerful turns. The HST motor speed is selected by pressing the shift button on top of the palm lever. A PPC valve integrated into the steering circuit facilitates smooth, shockless control.



Left Hand



Steering Functions

-  Forward and reverse
-  Right and left steering
-  First, to second, to third shifting



Right Hand

Blade Functions

-  Lifting and lowering
-  Tilting
-  Left and right angling

Easy-to-Operate, 3-Axis PPC Operated Implement Control Joystick

Newly developed 3-axis PPC valve and ergonomically designed PCCS joystick provide light operating effort and excellent blade response. There is no need to adjust mechanical linkage due to wear by replacing linkage with PPC valve.

CLSS Hydraulic System

With the hydraulic Closed-center Load Sensing System (CLSS), blade lever stroke is directly proportional with blade speed, regardless of the load and travel speed. This results in superb, fine controllability.

Benefits of CLSS

- More precise and responsive operation due to the pressure compensation valve.
- Reduced fuel consumption by discharging only the required amount of oil from the pump.
- Compound operations such as blade raise, tilt, and angle are easy due to CLSS parallel circuit with pressure compensation valve.

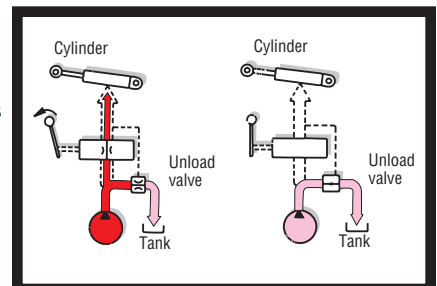

OPERATOR'S COMPARTMENT

Low-Noise Design

For smoother riding comfort, power train components and hydraulic control valves are mounted to the frame with rubber pads to soften vibration and shut out noise. Since the D31EX/PX-21 utilizes joysticks, the walk-through operator compartment is uncluttered for smooth entry and exit. A suspension seat with backrest is standard equipment.

Quadrangle Pressurized ROPS Cab (Optional)

This is another added comfort feature. Air filters and a higher internal air pressure combine to prevent external dust from entering the cab. In addition, the cab's design with a large one-piece front glass window provides excellent front, sides, and rear visibility. Cab features largest volume in its class, low noise 77 dB(A), and air vents arranged for optimum ventilation.

Fully adjustable suspension seat



Photo may include optional equipment.



Photo may include optional equipment.

Stepless Height Adjustable Armrests

Stepless height adjustable armrests and conveniently located fuel control lever provide comfortable operation and increase leg space.



Photo may include optional equipment.

ROPS cab (optional)



Photo may include optional equipment.

MAINTENANCE FEATURES

Electronic Monitoring System

An electronic monitoring system prevents minor problems from developing into major ones. All meters and gauges are controlled by a microcomputer, which provides a wide indication range for an easier, more precise reading.



- Battery Charge Light
- Engine Oil Pressure Caution Light
- Engine Water Temperature Gauge
- Fuel Gauge
- HST Gear Indicator
- HST Oil Temperature Gauge
- HST Charge Filter Caution Light
- Intake Air Heater Light
- Service Meter



Gull-Wing Engine Side Covers

With a gas-spring cylinder that opens 140°, the engine and the auxiliary components can be checked easily.



Daily maintenance items are centralized on left side of engine.



Reservoir

A radiator coolant reservoir makes it easier to check the coolant level and eliminates frequent refilling.



Travel Motors

Travel motors are installed inside the rear of main/track frame for ease of removal and installation.

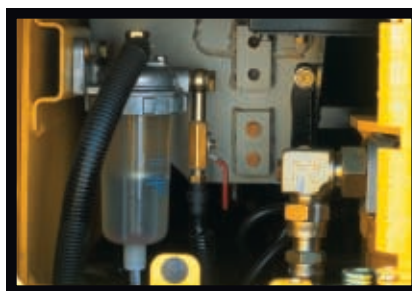

Easy Fuel Line Maintenance

D31EX/PX-21 KomStat uses a large size strainer on the fuel tank filler shortening fuel refill time. The water separator is standard equipment, preventing water mixing in fuel line. The fuel drain valve is located inside rear cover, facilitating fuel drainage.

Large Battery Doors

for easy access to batteries.

Extended Engine Oil Replacement Interval

Engine oil replacement interval is extended to 500 hours using a high performance engine oil filter.

Remote Lubrication to Blade Fulcrum Pins

Blade fulcrum pin grease fittings are remotely mounted beside engine side cover to improve accessibility.

HST Dynamic Brake

and wet type multiple-disc parking brake eliminate brake adjustment for maintenance-free operation.

Tow Valve

Tow valve opens brake circuit manually to tow tractor when engine is stopped.

UNDERCARRIAGE AND FRAME

Frame

Durable and Reliable Main Frame

D31EX/PX-21 main frame is designed by the same advanced Computer Aided Engineering (CAE) technology used on the D575A (the largest bulldozer in the world). This main frame structural feature is a main frame and track frame combined with connecting bars by welding, providing the ideal stiffness required in a small size crawler dozer.

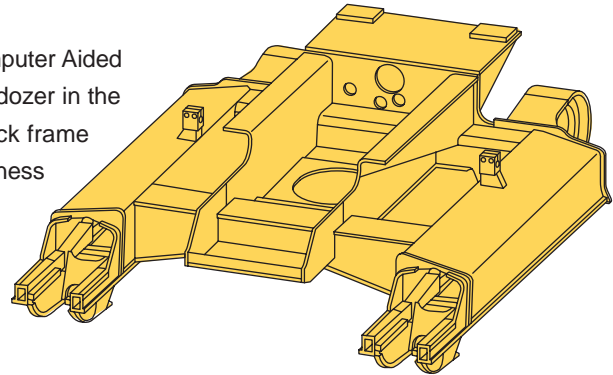

Travel Motors and Final Drives

Travel motors and final drives are mounted inside the track shoe for protection from rocks and stumps, and for improving durability.

Undercarriage

Durable and Reliable Undercarriage

Life of undercarriage and reliability are greatly extended by use of large size links, pins, bushings, and unique dust seals.



Photo may include optional equipment.

O-ring Face-Seal

O-rings in hydraulic circuits are mounted with face contact to prevent oil leak from vibration.

SPECIFICATIONS



ENGINE

Model Komatsu SAA4D102E-2
 Type Water-cooled, 4-cycle, emissionized
 Aspiration Turbocharged and air-cooled aftercooler
 Number of cylinders 4
 Bore 102 mm **4.02"**
 Stroke 120 mm **4.72"**
 Piston displacement 3.9 ltr **240 in³**
 Horsepower rating @2000 rpm (SAE J1349):
 Gross power 59.7 kW **80 HP**
 Flywheel/net power* 56 kW **75 HP**
 DIN 6270 56 kW **86 PS**
 Net maximum torque:
 D31EX/PX-21 384 N•m 39.2 kgf•m **284 lb•ft** @ 1300 rpm
 Governor All-speed, mechanical
 Filter Full-flow
 Direct injection fuel system. All-speed mechanical governor.
 Forced lubrication driven by gear pump. Full-flow for lube purification. Dry-type air cleaner with automatic dust evacuator and dust indicator. 5.5 kW/24 V electric starter motor.
 25 A/24 V alternator. 60 Ah/2 x 12 V batteries.

* Net flywheel horsepower output for standard engine (SAE J1349) including air cleaner, alternator (not charging), water pump, lubricating oil pump, fuel pump, muffler, and fan.



KOMSTAT HYDROSTATIC TRANSMISSION

Dual-path, hydrostatic transmission provides infinite speed change up to 8.5 km/h **5.3 mph**. The 3-speed variable capacity travel motors allow the operator to select the optimum speed to match specific jobs. Safety lock lever and neutral safety switch prevent machine from starting accidentally.

Travel speed	Forward	Reverse
1st	0–4.3 km/h 0–2.7 mph	0–4.3 km/h 0–2.7 mph
2nd	0–6.5 km/h 0–4.0 mph	0–6.5 km/h 0–4.0 mph
3rd	0–8.5 km/h 0–5.3 mph	0–8.5 km/h 0–5.3 mph

Maximum drawbar pull:

D31EX-21 123 kN 12500 kgf **27,560 lb**
 D31PX-21 123 kN 12500 kgf **27,560 lb**



STEERING SYSTEM

Palm Command Control System (PCCS) joystick control for all directional movements. Pushing the joystick forward results in forward machine travel, while pulling it rearward reverses the machine. Simply tilt the joystick to the left to make a left turn. Tilt it to the right for a right turn. Hydrostatic steering eliminates steering clutches and brakes, providing smooth powerful turns. A PPC valve integrated into the steering circuit facilitates smooth, shockless control. The PCCS utilizes shift buttons to increase and decrease speed.

Minimum turning radius:

D31EX-21 2250 mm **7'5"**
 D31PX-21 2550 mm **8'4"**

(As measured by track marks on the ground)



FINAL DRIVE

Two-stage planetary gear integrated into axial piston travel motors. Compact in-shoe mount reduces risk of damage by debris. Bolt-on sprockets for easy replacement.



UNDERCARRIAGE

Suspension Rigid type
 Track roller frame Box section, high-tensile-strength steel structure
 Rollers and idlers Lubricated idlers/carrier rollers, track rollers are sealed with floating seals
 Lubricated tracks:
 Unique dust seals for preventing entry of foreign abrasive into pin-to-bushing clearance for extended service. Track tension easily adjusted with grease gun.

	D31EX-21 KomStat	D31PX-21 KomStat
Number of carrier rollers (each side)	1	1
Number of track rollers (each side)	5	6
Number of shoes (each side)	38	40
Grouser height	47 mm 1.9"	47 mm 1.9"
Shoe width (standard)	400 mm 16"	600 mm 24"
Ground contact area	16100 cm ² 2,496 in²	26200 cm ² 4,061 in²
Ground pressure (bulldozer)	43 kPa 0.44 kgf/cm ² 6.26 psi	28 kPa 0.29 kgf/cm ² 4.12 psi
Track gauge	1450 mm 4'9"	1650 mm 5'5"
Length of track on ground	2010 mm 6'7"	2185 mm 7'2"



COOLANT AND LUBRICANT CAPACITY (REFILL)

Coolant 27 ltr **7.1 U.S.gal**
 Fuel tank 165 ltr **43.6 U.S. gal**
 Engine oil 12.5 ltr **3.3 U.S. gal**
 Hydraulic tank 47 ltr **12.4 U.S. gal**
 Final drive (each side) 3.5 ltr **0.9 U.S. gal**



OPERATING WEIGHT (APPROXIMATE)

Tractor weight:
 Including rated capacity of lubricant, coolant, full fuel tank, operator, and standard equipment.
 D31EX-21 5775 kg **12,730 lb**
 D31PX-21 6220 kg **13,710 lb**

Operating weight:
 Including power angle tilt dozer, ROPS canopy, operator, standard equipment, rated capacity of lubricant, coolant, and full fuel tank.
 D31EX-21 7130 kg **15,720 lb**
 D31PX-21 7650 kg **16,870 lb**



DIMENSIONS (POWER ANGLE TILT DOZER)

	D31EX-21		D31PX-21	
A	1255 mm	4'1"	1255 mm	4'1"
B	2435 mm	8'0"	3200 mm	10'6"
C	330 mm	1'1"	435 mm	1'5"
D	2700 mm	8'10"	2700 mm	8'10"
E	860 mm	2'10"	855 mm	2'10"
F	385 mm	1'3"	380 mm	1'3"
G	2010 mm	6'7"	2185 mm	7'2"
H	4015 mm	13'2"	3995 mm	13'1"
I	1605 mm	5'2"	1605 mm	5'2"
J	1890 mm	6'2"	1890 mm	6'2"
K	2700 mm	8'10"	2700 mm	8'10"
L	47 mm	1.9"	47 mm	1.9"
M	1450 mm	4'9"	1650 mm	5'5"
N	400 mm	16"	600 mm	24"
O	1850 mm	6'1"	2250 mm	7'5"
P	35 mm	1.4"	185 mm	7.3"
Q	2250 mm	7'5"	2935 mm	9'8"

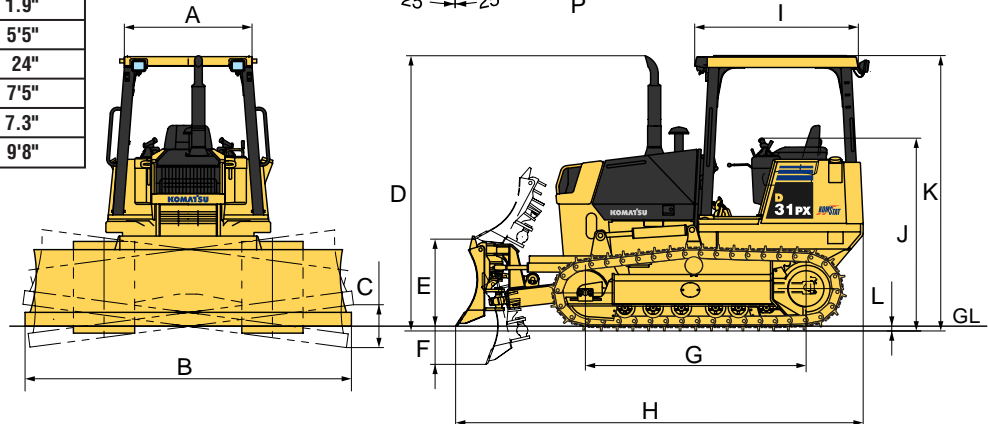
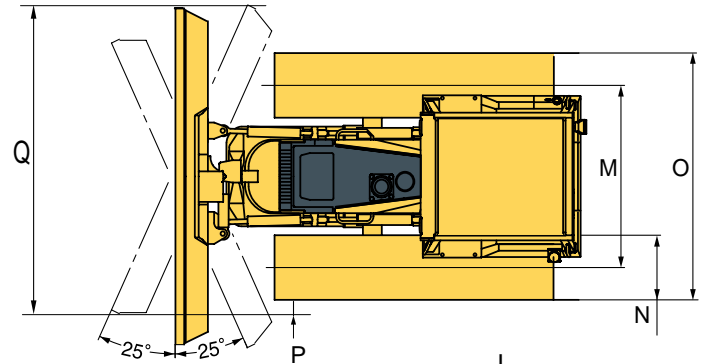

Ground clearance 315 mm 12.4"



HYDRAULIC SYSTEM

Closed-center Load Sensing System (CLSS) designed for precise and responsive control and for efficient simultaneous operation.

Hydraulic control unit:

All-spool control valves externally mounted beside the hydraulic tank. Gear-type hydraulic pump with capacity (discharge flow) of 76 ltr/min **20.1 U.S. gal/min** at rated engine rpm.

Relief valve setting 20.6 MPa 210 kg/cm² **2,990 psi**

Hydraulic cylinders. Double-acting, piston type

	Number of Cylinders	Bore
Blade lift	2	85 mm 3.35"
Blade tilt	1	90 mm 3.54"
Blade angle	2	75 mm 2.95"

Hydraulic oil capacity (refilling):

Power angle tilt dozer 47 ltr **12.4 U.S. gal**

Control valves:

3-spool control valve for power angle tilt dozer.

Positions:

Blade lift Raise, hold, lower, and float
Blade tilt Right, hold, and left
Blade angle Right, hold, and left

Additional control valve required for ripper.

Positions:

Ripper lift Raise, hold, and lower



DOZER EQUIPMENT (POWER ANGLE TILT DOZER)

	Overall Length With Dozer	Blade Capacity (SAE)	Blade Width x Height	Maximum Lift Above Ground	Maximum Drop Below Ground	Maximum Tilt Adjustment	Blade Angling Angle
D31EX -21 Power Angle Tilt Dozer	4015 mm 13'2"	1.26 m ³ 1.65 yd³	2435 mm x 845 mm 8'0" x 2'9"	860 mm 2'10"	385 mm 1'3"	330 mm 1'1"	25°
D31PX-21 Power Angle Tilt Dozer	3995 mm 13'1"	1.34 m ³ 1.75 yd³	3200 mm x 750 mm 10'6" x 2'6"	855 mm 2'10"	380 mm 1'3"	435 mm 1'5"	25°



STANDARD EQUIPMENT

- Air cleaner, double element with dust indicator
- Alternator, 35 ampere
- Backup alarm
- Batteries, 60 Ah/2 x 12 V
- Blower cooling fan
- Decelerator pedal
- Electronic instrument monitor panel
- Engine hood and gull-wing side covers
- Fenders
- Front pull hook
- High-mount footrests
- Intake pipe with precleaner
- Integrated double flange rollers
- Lighting system (includes 2 front, 1 rear)
- Muffler with curved exhaust pipe
- Palm Command Control System (PCCS)
- Radiator core protective grid
- Radiator guard door, bolt on
- Radiator reserve tank
- Rear cover
- Rearview mirror
- ROPS mounting brackets
- Seat belt, retractable
- Starting motor, 5.5 kW/24 V
- Suspension seat, reclining with headrest
- Track roller guard, end section
- Track shoe assembly
 - Sealed and lubricated track
 - 400 mm **16"** single grouser shoe (D31EX)
 - 600 mm **24"** single grouser shoe (D31PX)
- Underguards, oil pan and transmission
- Water separator



OPTIONAL EQUIPMENT

- Air conditioner
- Cab accessories
 - Additional lights
 - Sun visor
 - Lunch box holder
 - Radio, AM/FM
- Heater for cabless
- Hitch
- Hydraulics for ripper (D31EX)
- Multi-shank ripper (D31EX)
 - Additional weight (including hydraulic control unit) 575 kg **1270 lb**
 - Beam length 1530 mm **5'0"**
 - Maximum digging depth 315 mm **12.4"**
 - Maximum lift above ground 435 mm **1'5"**
- ROPS cab
 - Additional weight*, 650 kg **1,430 lb**
 - Meets ISO 3471, SAE J1040 APR88, and ISO 3449 FOPS standards.
 - All-weather, enclosed pressurized cab
 - Dimensions
 - Length: 1575 mm **5'2"**
 - Width: 1255 mm **4'1"**
 - Height: 1625 mm **5'4"**
 - Height from floor to ceiling 1515 mm **5'0"**
- *Including weight of air conditioner
- ROPS canopy
 - Additional weight 310 kg **680 lb**
 - Meets ISO 3471, SAE J1040 APR88, and ISO 3449 FOPS standards.
 - Roof dimension
 - Length: 1575 mm **5'2"**
 - Width: 1255 mm **4'1"**
 - Height from operator compartment floor 1575 mm **5'2"**
- Suspension seat
 - Reclining with fabric material and headrest (cab only)
- Sweeps and screens
- Track guard, full length, segmented
- Vandalism protection cover for instrument panel

ROPS cab or ROPS canopy must be ordered for all machines.

KOMATSU®

Komatsu America International Company
440 N. Fairway Dr., Vernon Hills, IL 60061

