

Technical Description Hydraulic Excavator

R 996
Litronic®

Operating Weight with Backhoe Attachment 650,6 t/1,434,350 lb
Operating Weight with Shovel Attachment 655,8 t/1,445,800 lb
Engine Output 3000 HP (2240 kW)
Bucket Capacity 25,00 - 33,00 m³/32.7 - 43.2 cuyd
Shovel Capacity 25,00 - 34,00 m³/32.7 - 44.5 cuyd



LIEBHERR

Technical Data



Engine

2 Cummins diesel engines	
Rating per SAE J 1995	3000 HP (2240 kW) at 1800 RPM
Model	K 1800 E
Type	16 cylinder V-engine, water-cooled, direct injection, turbo-charged, after-cooler
Displacement	50,3 l/3069 cu.in
Bore/Stroke	159/159 mm/6.26/6.26 in
Air cleaner	dry-type air cleaner with pre-cleaner, with automatic dust ejector, primary and safety elements
Fuel tank	13 000 l/3440 gal
Electrical system	
Voltage	24 V
Batteries	8 x 170 Ah/12 V
Alternator	2 x 24 V/150 Amp
Engine idling	sensor controlled



Hydraulic System

Hydraulic pumps for attachment and travel drive	8 variable flow axial piston pumps
Max. flow	8 x 840 l/min/8 x 222 gpm
Max. hydr. pressure	320 bar/4640 PSI
Hydraulic pumps for swing drive	4 reversible swash plate pumps, closed-loop circuit
Max. flow	4 x 413 l/min/4 x 109 gpm
Max. hydr. pressure	350 bar/5076 PSI
Pump regulation	electro-hydraulic, pressure compensation, flow compensation, automatic oil flow optimizer
Hydraulic tank capacity	4600 l/1215 gal
Hydraulic system capacity	8200 l/2166 gal
Hydraulic oil filter	filtration of entire return flow, 1 high pressure filter for each main pump
Hydraulic oil cooler	2 separate coolers, 4 temperature controlled fans driven via hydraulic piston motors
Electronic engine speed sensing	over the entire engine RPM range
Lubrication	central lubrication system



Hydraulic Controls

Servo circuit	independent, electric over hydraulic proportional controls of each function
Emergency control	via accumulator for all attachment functions with stopped engine
Power distribution	via monoblock control valves with integrated primary relief valves and flanged on secondary valves for travel
Flow summation	to attachment and travel drive
Control functions	
Attachment and swing	proportional via joystick levers
Travel	proportional via foot pedals or hand levers
Bottom dump bucket	proportional via foot pedals
Operation with one engine possible	



Swing Drive

Hydraulic motor	4 Liebherr axial piston motors
Swing gear	4 Liebherr planetary reduction gears
Swing ring	Liebherr, sealed triple roller swing ring, internal teeth
Swing speed	0-3.5 RPM
Swing-Holding brake	hydraulically released, maintenance-free, multi-disc brakes integrated in each swing gear



Uppercarriage

Design	torque resistant designed upper frame in box type construction for superior strength and durability
Attachment mounting	parallel longitudinal main girders in box-section construction
Catwalks	on the right side with a hydraulically driven access ladder, additional emergency ladder in front of the cab



Service Flap

Design	hydraulically actuated service flap, easily accessible from ground level to allow: <ul style="list-style-type: none">- fuel fast refill- hydraulic oil refill- engine oil quick change- splitterbox oil quick change- swing gearbox oil quick change- windshield washer water refilling
Quick coupler	upon request

Technical Data



Operator's Cab

Design	resiliently mounted, sound insulated, large windows for all-around visibility, integrated falling object protection FOPS
Operator's seat	suspended, body-contoured with shock absorber, adjustable to operator's weight
Cabin windows	20,5 mm/0.8 in tinted armored glass for front window and left hand side windows, all other windows in tinted safety glass, high pressure windshieldwasher-system with 75 l/20 gal watertank, sun louvers on all windows in heavy duty design
Heating system/ Air conditioning	heavy duty, high output air conditioner and heater unit
Cabin pressurization	ventilation unit with filters
Controls	joystick levers integrated into armrest of seat
Monitoring	via LCD-Display, data memory
Automatic engine shut off	in case of low engine oil pressure or low coolant level
Destroking of main pumps	in case of engine overheating or low hydraulic oil level
Safety functions	additional gauges with constant display for: engine speed, hourmeter, engine oil pressure, coolant temperature and hydraulic oil temperature



Undercarriage

Design	3-piece undercarriage, box type structures for center piece and side frames, stress relieved
Hydraulic motor	2 axial piston motors per side frame
Travel gear	Liebherr reduction gear
Travel speed	0–2,2 km/h/0–1.4 mph
Parking brake	spring engaged, hydraulically released wet multi-disc brakes for each travel motor, maintenance-free
Track components	maintenance-free combined pad-link, heavy duty track shoes
Track rollers/ Carrier rollers	7/3
Automatic track tensioner	pressurized hydraulic cylinder with accumulator, maintenance free
Transport	undercarriage side frames are removable



Central Lubrication System

Type	Lincoln Centromatic lubrication system for the entire attachment and swing ring
Grease pumps	2 Lincoln Powermaster pumps with switch over function, plus 1 separate pump for swing ring teeth
Capacity	1 x 600 l/158.5 gal bulk container for attachment and swing ring, separated 1 x 80 l/21 gal grease drum for swing ring teeth



Attachment

Design	box type structure with large steel castings in all high-stress areas
Pivots	sealed with double side centering with 1 single floating pin per side, all bearings with wear resistant, steel bushings, bolts hardened and chromium-plated
Hydraulic cylinders	Liebherr design, all cylinders located in well protected areas
Hydraulic connections	pipes and hoses equipped with SAE split flange connections
Kinematics	Liebherr parallel face shovel attachment geometry

Dimensions

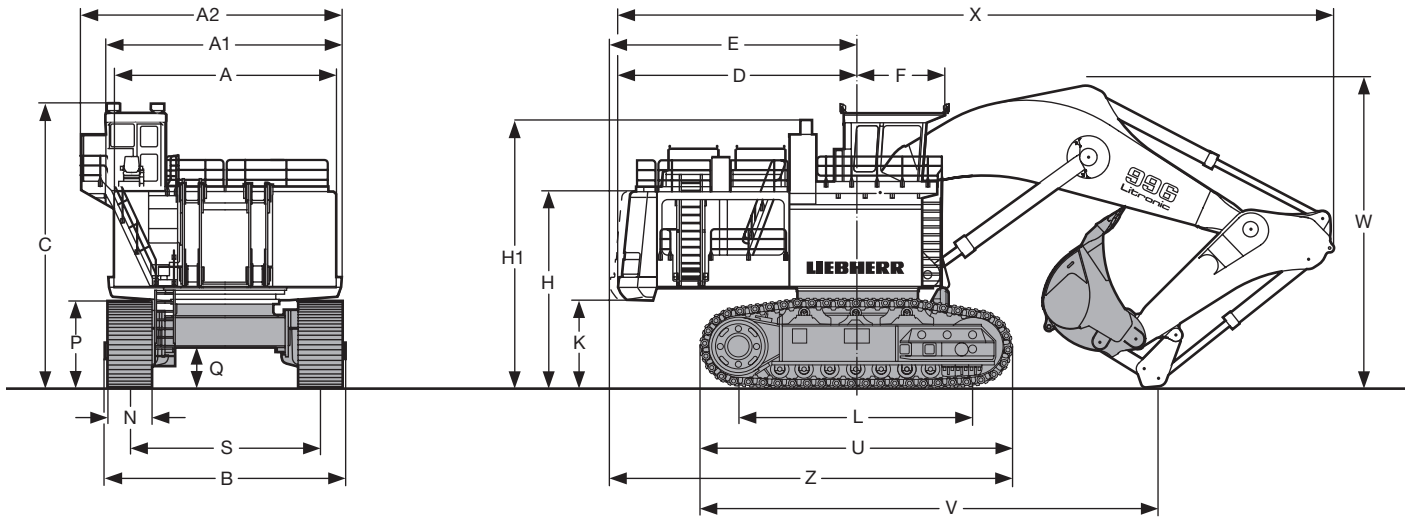

	mm/ft-in
A	7000/22' 11"
A1	7430/24' 4"
A2	8250/27' 1"
B	7650/25' 1"
C	9070/29' 9"
D	7550/24' 9"
E	7795/25' 7"
F	2780/ 9' 1"
H	6275/20' 7"
H1	8480/27' 10"
K	2845/ 9' 4"
L	7500/24' 7"
U	10000/32' 9"

	mm/ft-in
P	2985/ 9' 9"
Q	1435/ 4' 8"
S	6000/19' 8"
N	1400/ 55"
W	9750/32' 0"
V	14350/47' 1"
X	22600/74' 1"
Z	12465/40' 10"

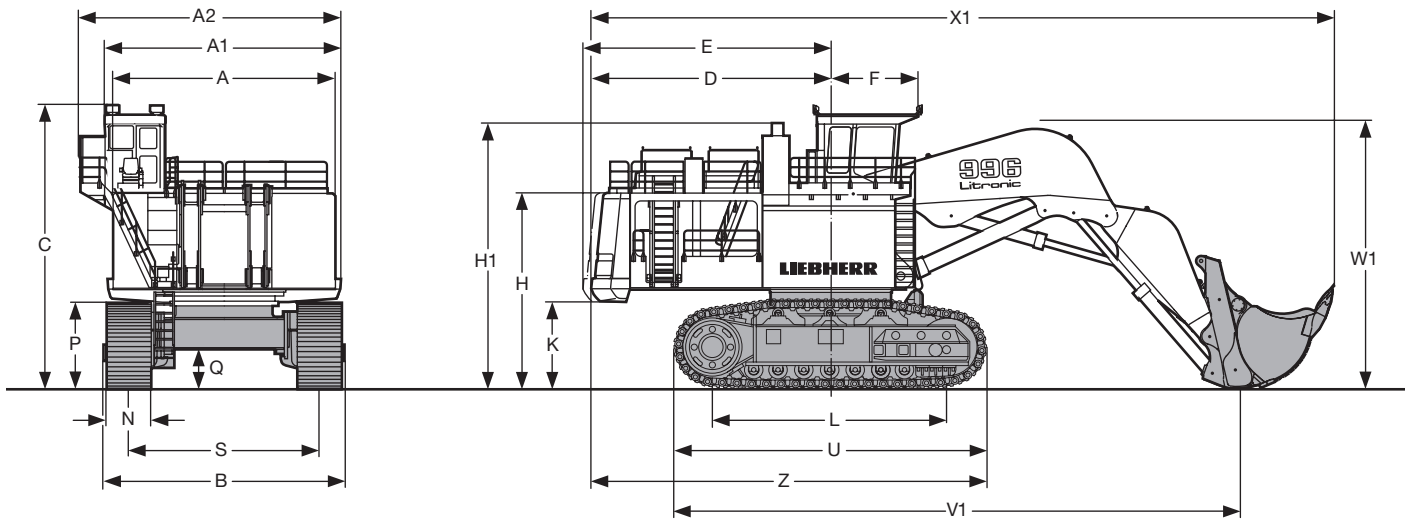

	mm/ft-in
A	7000/22' 11"
A1	7430/24' 4"
A2	8250/27' 1"
B	7650/25' 1"
C	9070/29' 9"
D	7550/24' 9"
E	7795/25' 7"
F	2780/ 9' 1"
H	6275/20' 7"
H1	8480/27' 10"
K	2845/ 9' 4"
L	7500/24' 7"
U	10000/32' 9"

	mm/ft-in
P	2985/ 9' 9"
Q	1435/ 4' 8"
S	6000/19' 8"
N	1400/ 55"
W1	8500/27' 10"
V1	17800/58' 4"
X1	23450/76' 11"
Z	12465/40' 10"

Backhoe Attachment

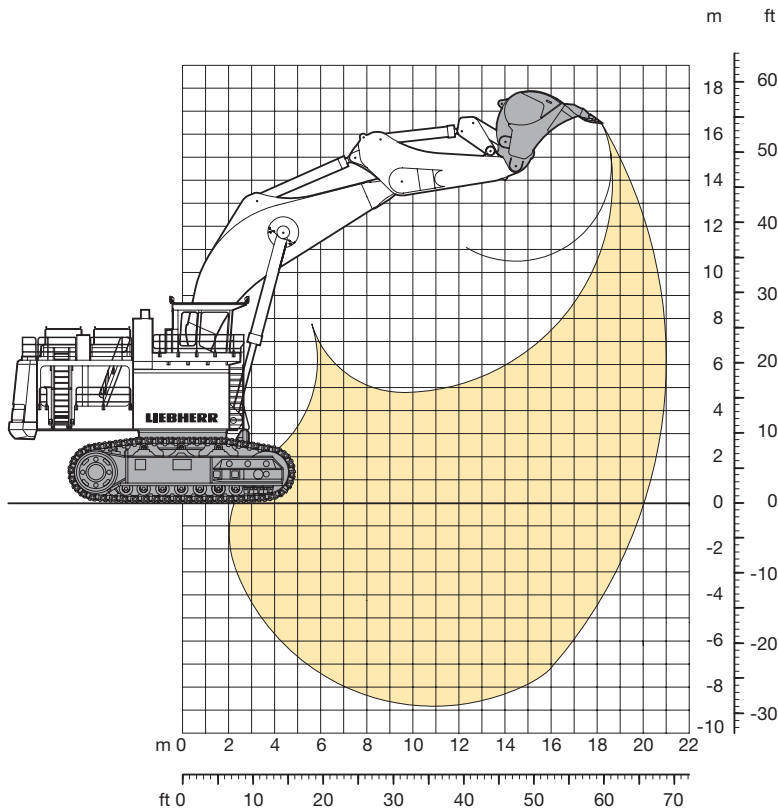

Digging envelope

Max. reach at ground level	20,00 m/65' 7"
Max. teeth height	16,60 m/54' 5"
Max. dump height	10,50 m/34' 5"
Max. digging depth	8,80 m/28' 10"
Max. digging force	1500 kN (153,0 t)/337,100 lb
Max. breakout force	1670 kN (170,2 t)/375,300 lb

Operating Weight and Ground Pressure

The operation weight includes the basic machine with backhoe attachment and bucket 30,00 m³/39.2 cuyd.

Pad width	mm/in	1400/55
Weight	kg/lb	650600/1,434,350
Ground pressure	kg/cm ² /PSI	2,77/39.40

Bucket

Cutting width SAE	mm/in	4150/163 ¹⁾	4700/185 ¹⁾	4700/185 ¹⁾
Capacity SAE heaped	m ³ /cuyd	25,00/32.7	30,00/39.2	33,00/43.1
Weight	kg/lb	35000/77,160	39000/85,980	40000/88,180
Suitable for material up to a specific weight of	t/m ³ /lb/cuyd	2,20/3700	1,80/3000	1,60/2700
Wear kit level		III	II	II

¹⁾ Bucket with delta cutting edge and tooth system Posilok size S 145.

Level II: For heavy rock, not deteriorated or cracked. Has to be shot to be dug.

Level III: For highly-abrasive materials such as rock with a high silica content, sandstone etc.

Shovel Attachment

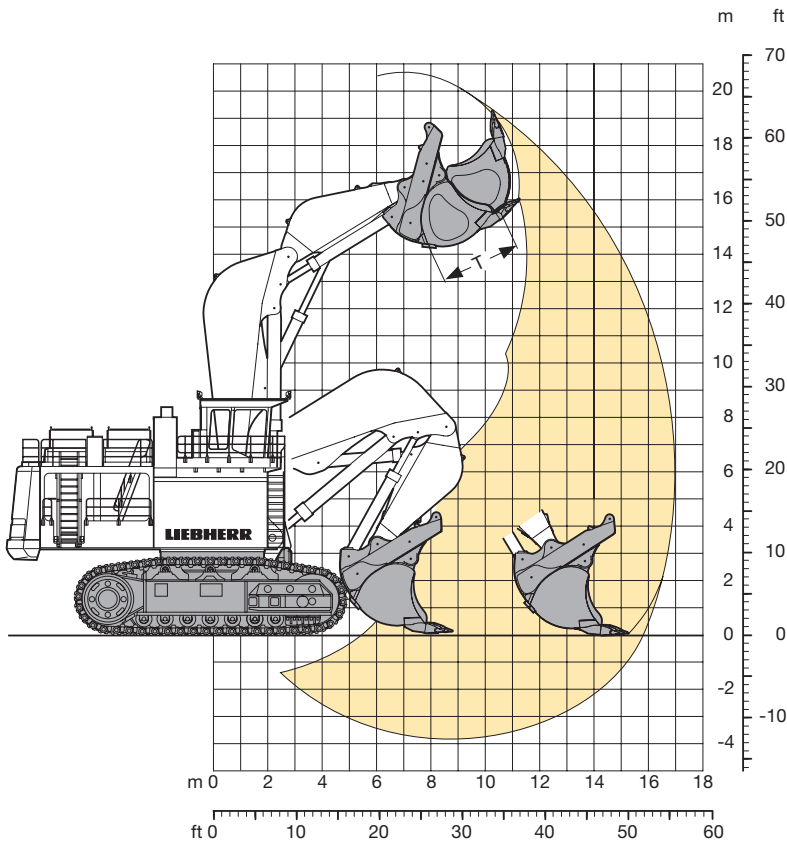

Digging Envelope

Max. reach at ground level	15,60 m/51' 2"
Max. dump height	14,30 m/46'11"
Max. crowd length	6,40 m/21' 0"
Bucket opening width T	2800 mm/110"
Crowd force at ground level	1960 kN (199,8 t)/440,450 lb
Max. crowd force	2340 kN (238,5 t)/525,850 lb
Max. breakout force	1905 kN (194,2 t)/428,100 lb

Operating Weight and Ground Pressure

The operation weight includes the basic machine with shovel attachment and bottom dump bucket 34,00 m³/44.4 cuyd.

Pad width	mm/in	1400/55
Weight	kg/lb	655800/1,445,800
Ground pressure	kg/cm ² /PSI	2,79/39.68

Bottom Dump Bucket

Cutting width SAE	mm/in	4150/163 ¹⁾	4700/185 ¹⁾	5500/217 ¹⁾
Capacity SAE heaped	m ³ /cuyd	25,00/32.7	29,00/37.9	34,00/44.4
Weight	kg/lb	49050/108,130	53600/118,160	59400/130,950
Suitable for material up to a specific weight of	t/m ³ /lb/cuyd	2,60/4400	2,20/3700	1,80/3000
Wear kit level		III	II	II

¹⁾ Bottom dump bucket with delta cutting edge and tooth system Posilok size S 145

Level II: For heavy rock, not deteriorated or cracked. Has to be shot to be dug.

Level III: For highly-abrasive materials such as rock with a high silica content, sandstone etc.

Component Dimensions and Weights

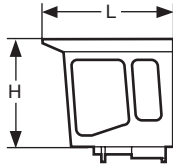

Cab

L Length	mm/ft-in	3215/10' 6"
H Height	mm/ft-in	2885/ 9' 6"
Width	mm/ft-in	1900/ 6' 3"
Weight	kg/lb	2800/6,200

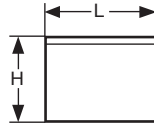

Cab Elevation with Fuel Tank

L Length	mm/ft-in	4150/13' 7"
H Height	mm/ft-in	3100/10' 2"
Width	mm/ft-in	2700/ 8'10"
Weight	kg/lb	8000/17,650

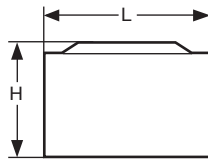

Powerpack Modules (two)

L Length	mm/ft-in	5280/17' 4"
H Height	mm/ft-in	3640/11'11"
Width	mm/ft-in	2070/ 6' 9"
Weight	kg/lb	2 x 22000/2 x 48,500

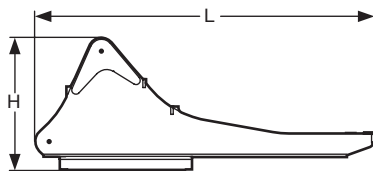

Rotation Deck (with swing ring, swing gears and control valve bracket)

L Length	mm/ft-in	9750/32' 0"
H Height	mm/ft-in	4250/13'11"
Width	mm/ft-in	4270/14' 0"
Weight	kg/lb	77800/171,500

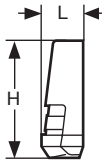

Counterweight

L Length	mm/ft-in	1250/ 4' 1"
H Height	mm/ft-in	3430/11' 3"
Width	mm/ft-in	7360/24' 2"
Weight	kg/lb	60000/132,300

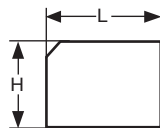

Hydraulic Oil Cooling with hydraulic tank without hydraulic oil

L Length	mm/ft-in	4210/13'10"
H Height	mm/ft-in	3100/10' 2"
Width	mm/ft-in	2100/ 6'11"
Weight	kg/lb	8000/17,650

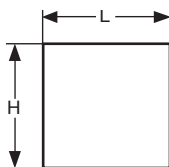

Compartment Panel (two)

L Length	mm/ft-in	4145/13' 7"
H Height	mm/ft-in	3100/10' 2"
Width	mm/ft-in	950/ 3' 1"
Weight	kg/lb	2 x 1500/2 x 3,300

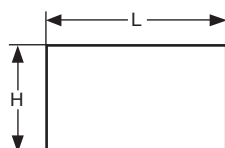

Miscellaneous

L Length	mm/ft-in	4500/14' 9"
H Height	mm/ft-in	2600/ 8' 6"
Width	mm/ft-in	2000/ 6' 7"
Weight	kg/lb	5000/11,100

Component Dimensions and Weights

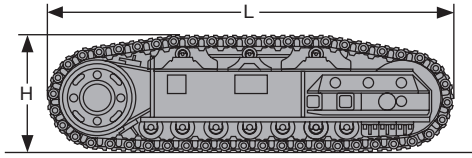

Side Frame (two)

L Length	mm/ft-in	10000/32' 9"
H Height	mm/ft-in	2985/ 9' 9"
Width over travel drive	mm/ft-in	2700/ 8'11"
Width without travel drive	mm/ft-in	2225/ 7' 4"
Weight	kg/lb	2 x 117000/2 x 258,000

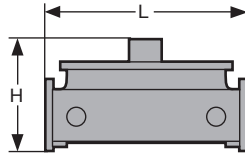

Undercarriage Central Girder

L Length	mm/ft-in	4000/13' 1"
H Height	mm/ft-in	2690/ 8'10"
Width	mm/ft-in	4600/15' 1"
Weight	kg/lb	40000/88,200

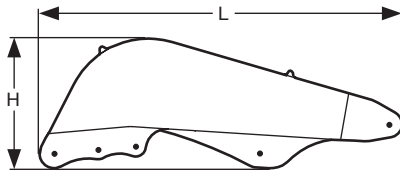

Shovel Boom

L Length	mm/ft-in	8650/28' 4"
H Height	mm/ft-in	3300/10'10"
Width	mm/ft-in	3350/11' 0"
Weight	kg/lb	53240/117,400

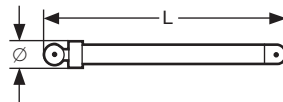

Hoist Cylinder (two)

L Length	mm/ft-in	5430/17'10"
Ø Diameter	mm/in	600/00'24"
Weight	kg/lb	2 x 5600/2 x 12,350

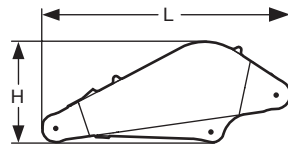

Shovel Stick

L Length	mm/ft-in	5620/18' 5"
H Height	mm/ft-in	2300/ 7' 6"
Width	mm/ft-in	3350/11' 0"
Weight	kg/lb	27150/59,850

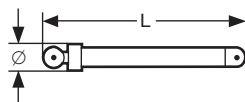

Crowd Cylinder (two)

L Length	mm/ft-in	3880/12' 9"
Ø Diameter	mm/in	490/00'19"
Weight	kg/lb	2 x 3430/2 x 7,560

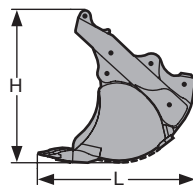

Bottom Dump Bucket (including clam cylinders)

Cutting width	mm/in	4150/163"	4700/185"	5500/217"
Capacity	m ³ /cuyd	25,00/32.7	29,00/37.9	34,00/44.4
L Length	mm/ft-in	4650/15'3"	4650/15'3"	4650/15'3"
H Height	mm/ft-in	4500/14'9"	4500/14'9"	4500/14'9"
Width	mm/ft-in	4150/13'7"	4700/15'5"	5500/18'0"
Weight	kg/lb	49050/108,130	53600/118,160	59400/130,950

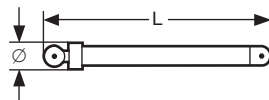

Bucket Tilt Cylinder (two)

L Length	mm/ft-in	4690/15' 5"
Ø Diameter	mm/in	490/00'19"
Weight	kg/lb	2 x 3670/2 x 8,090

Component Dimensions and Weights

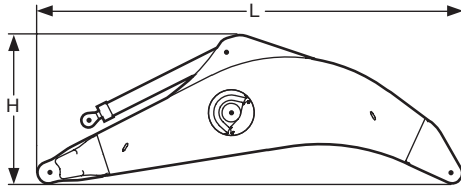

Gooseneck Boom with Two Stick Cylinders

L Length	mm/ft-in	12500/41' 0"
H Height	mm/ft-in	4500/14' 9"
Width	mm/ft-in	2800/ 9' 2"
Weight	kg/lb	68950/152,000

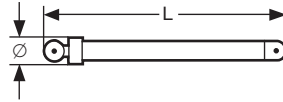

Hoist Cylinders (two)

L Length	mm/ft-in	5430/17'10"
Ø Diameter	mm/in	600/00'24"
Weight	kg/lb	2 x 5600/2 x 12,350

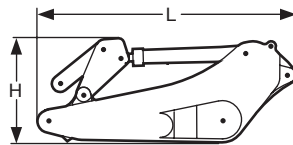

Stick with Two Bucket Cylinders

L Length	mm/ft-in	7500/24' 7"
H Height	mm/ft-in	3000/ 9'10"
Width	mm/ft-in	2500/ 8' 2"
Weight	kg/lb	40800/89,950

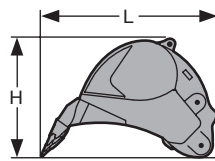

Backhoe Buckets

Cutting width	mm/in	4150/163"	4700/185"	4700/185"
Capacity	m ³ /cuyd	25,00/32.7	30,00/39.2	33,00/43.1
L Length	mm/ft-in	4650/15'3"	4650/15'3"	4650/15' 3"
H Height	mm/ft-in	3150/10'4"	3150/10'4"	3300/10'10"
Width	mm/ft-in	4200/13'9"	4750/15'7"	4750/15' 7"
Weight	kg/lb	35000/77,150	39000/86,000	40000/88,200

Liebherr-France SAS

2, Avenue Joseph Rey, B.P. 287, F-68005 Colmar Cedex

☎ +33 (0)389 21 35 10, Fax +33 (0)389 21 37 93

www.liebherr.com, E-Mail: info@lfr.liebherr.com